

Drywall Grid System Technical Guide Flat Ceilings

Armstrong[®]
CEILING SOLUTIONS

DRYWALL GRID SYSTEM



Flat Ceilings

Drywall Grid Systems

Features and Benefits

Armstrong Drywall Grid is fast and easy to install and an economical alternative to TCR and Furring Channel construction.

Applications

Armstrong Drywall Grid Systems offer flexible design solutions for:

- Flat and Curved Ceilings
- Bulkheads (Multiple Step and Curved)
- Transitions to Acoustical Ceilings
- Margins
- Perimeters
- Walls

Features

- **PeakForm**
Patented profile increases strength and stability for improved performance during installation
- **Knurled Face**
Positive screw penetration into tees
- **SuperLock / XL²**
Main Bar and Cross Runner clips are engineered for a strong secure connection and fast accurate alignment confirmed with an audible click; easy to remove and relocate
- **ScrewStop**
Reverse hem prevents screw spin off on Tee face
- **38mm Wide Face**
Main Bars and Cross Runners – easy installation of screw fixed plasterboard sheets
- **Rotary stitched Double Thickness Web**
For additional torsional strength and stability
- **Simple Integration of Mechanical Services**

Benefits

- Reduced installation time
- Reduced labour costs
- Reduced material costs and wastage
- Low 38mm profile across one plane
- Material off cuts can be used for bracing and as an alternative suspension method

Physical Data

- Material: Hot dipped galvanised steel
- Recycled Content: 25%
- Surface Finish: Z275 galvanised
- Main Bar / Cross Runner Interface: Joggled ends
- End Detail:
 - Main Bar: staked-on SuperLock clip
 - Cross Runner: staked-on XL² clip

Code Compliance

Armstrong DGS is designed and manufactured to comply with the following standards:

AS/NZS 2785-2020: Suspended Ceilings – Design and Installation

AS/NZ 2589-2007: Gypsum linings – Application and finishing

AS/NZ 1397-2002: Steel sheet and strip – Hot-dipped zinc-coated or aluminium/zinc-coated

AS/NZ 4600-2005: Cold-formed steel structures

AS/NZ 1170-2002: Structural Design Actions

Flat Ceilings

The Drywall Grid System is made up of Main Bars and Cross Runners that are suspended from the structural deck. Sections of Main Bars lock together end-to-end with Cross Runners spanning between the Main Bars.

The ends of the Main Bars and Cross Runners either lock into the wall Channel or are fixed to Angle Trims that run around the perimeter of the space.

Features

- Simple “two way” grid system for interior screw up ceilings
- Solutions for Bulkheads/special transitions
- Integration between plasterboard and acoustical panel ceilings
- Complete range of perimeter solutions including Pelmet

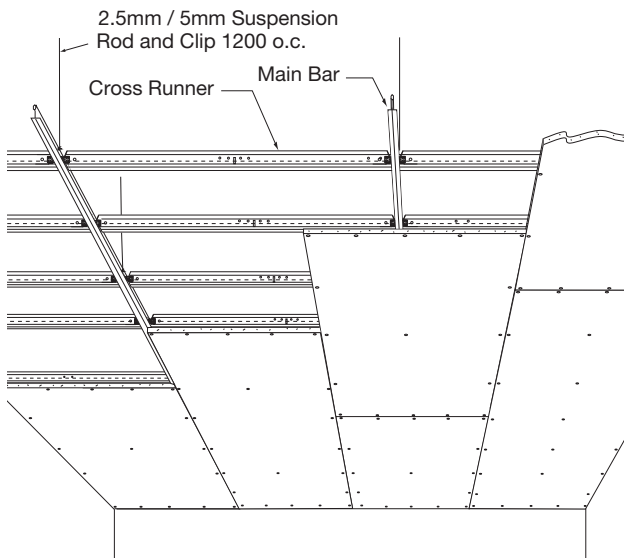

Main Bar: PeakForm 38 with Knurled Face and SuperLock Clip (bulb-to-bulb connection)

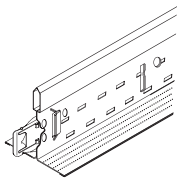

Item Number	Dimensions			Rout Spacing mm	Content / Carton / Weight		
	length (mm)	height (mm)	face (mm)		pcs	lm	kg
BP 794033	3600	38	38	150cc	12	43.2	24

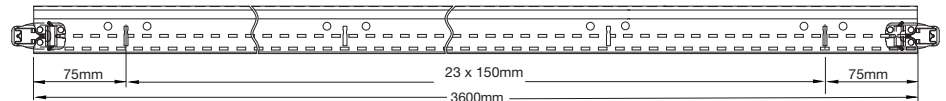

Cross Runners: PeakForm 38 XL² with Knurled Face (stab connection, override)

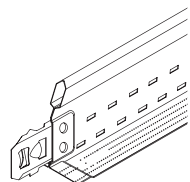

Item Number	Dimensions			Rout Spacing mm	Content / Carton / Weight		
	length (mm)	height (mm)	face (mm)		pcs	lm	kg
BP 793033	1200	38	38	Centre	36	43.20	21
BP 793133	1250	38	38	Centre	36	45.0	22
BP 796133	1600	38	38	Centre	36	57.6	24

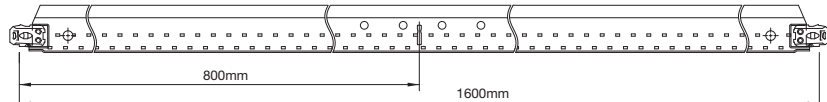
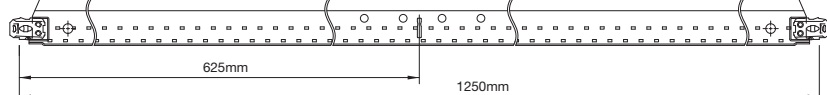
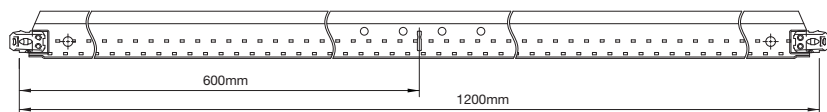

Flat Ceilings

Perimeter Trims

A variety of drywall grid perimeter trims and accessories are available to provide problem-solving solutions that save time, labor and money.

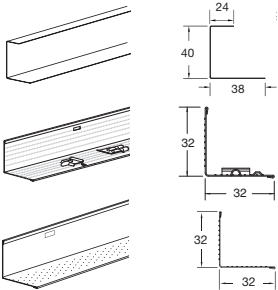

Item Number	Dimensions			Rout Spacing mm	Content / Carton / Weight		
	length (mm)	height (mm)	face (mm)		pcs	lm	kg
Knurled Channel Moulding (hemmed with Knurled lower leg) BP KCM 36	3600	40	38	-	12	43.2	15.6
Locking Angle Trim (hemmed with Knurled faces) BP LAT36	3600	32	32	75 in / 150 o.c.	20	72	26
Angle Trim (hemmed with Knurled faces) BP KAM36	3600	32	32	-	20	72	26

Transition Trims

An innovative transition solution from flush plasterboard to acoustical ceiling systems.

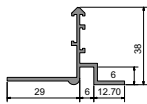
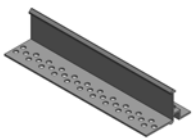

Plasterboard Transition Set Bead With 6mm Reveal - Satin White

Item Number	Dimensions			Rout Spacing mm	Content / Carton / Weight		
	length (mm)	height (mm)	face (mm)		pcs	lm	kg
ALPTPERFTH3600	3600	38	45.5	-	20	72	24

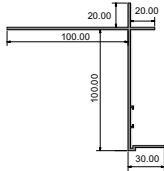
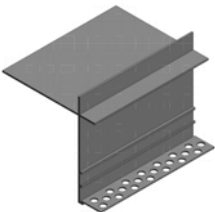

2 sided Pelmet with Set Edge - Satin White

Item Number	Dimensions			Rout Spacing mm	Content / Carton / Weight		
	length (mm)	height (mm)	face (mm)		pcs	lm	kg
PLMR100	3600	100	100	-	4	14.4	28

Pelmets/Trims are secured to Drywall Grid with Roll In Clip (Item: ALRIC)

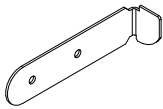

Item Number	Dimensions			Rout Spacing mm	Content / Carton / Weight		
	length (mm)	height (mm)	face (mm)		pcs	lm	kg
ALRIC	65	16	-	-	100	-	5

Construction Detail/Application

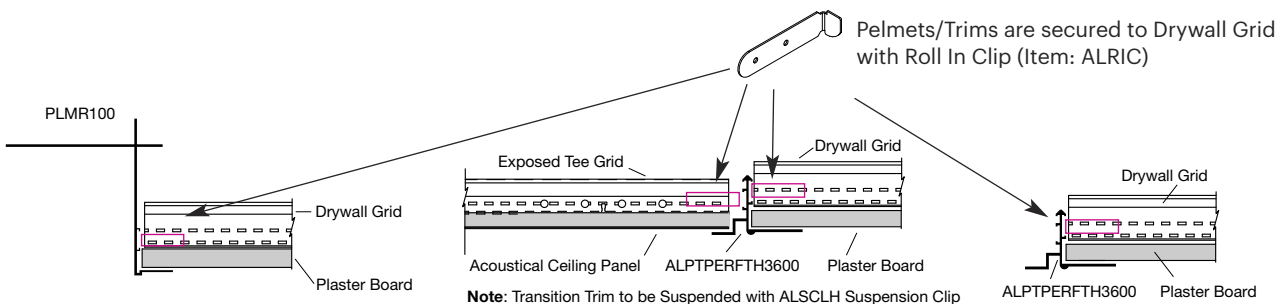

Grid Accessories

LEGEND: ● Flat Ceilings, ● Wall systems, ● Curved Ceilings, ● Quikstix Bulkheads, ● ShortSpan

Application

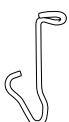
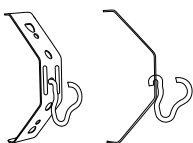
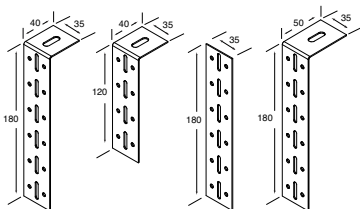
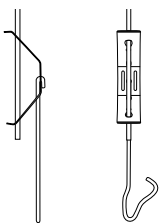
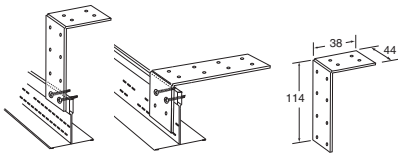
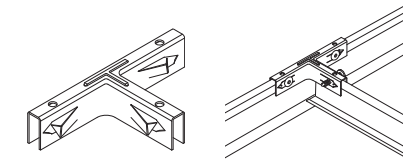
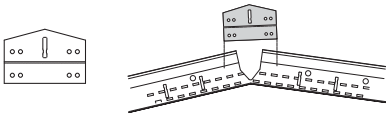
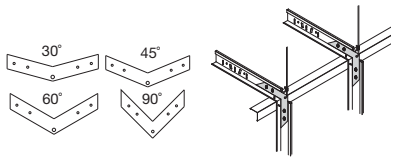
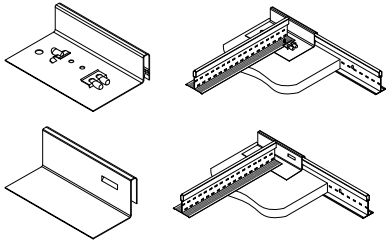

Item Number	Product Description	Pcs / Bucket	Legend
BPDW10LT BPDW13LT BPDW16LT ALDW13	Transition Clips with Locking Tabs facilitate transition from drywall to acoustical ceiling; one-sided hold-down clip; eliminates need for drywall bead. Locking tabs provide secure location for DGS tees For 10mm Plasterboard For 13mm Plasterboard For 16mm Plasterboard Suits 45/50 Top Hat for 13mm Plasterboard	125 125 125 100	● ● ● ●
BPDW30C BPDW45C BPDW60C BPDW90C	30, 45, 60 and 90 degree Drywall Angle Clips are used to create positive and secure angles for drywall and ceiling installations on either Main Bars or Cross Runners	250 250 250 250	● ● ● ●
BPRC2	Radius Clip is used to secure the Main Bar at the desired angle in curved ceiling applications. Includes a rout for Cross Runners installation	205	●
BPGC3W	3 Way Bite Clip connects Intersecting Cross Runners at any point along a Main Bar or other Cross Runners	250	● ● ●
BPQSUTC*	Up Tight Clip is used for Direct fix applications *Non stock item – lead time required	150	● ● ● ● ●
SCDGS	Rod Hanging Clip is the standard height adjustable suspension clip connecting from 2.5mm or 5mm rod to the DGS Main Bar	100	● ● ●
DWDFC DWDFC120 DWDFC180 DWDFC18050	Direct Fix Clip – 180mm L Shape Direct Fix Clip – 120mm L Shape Direct Fix Clip – 180mm Flat Extension Direct Fix Clip – 180mm L Shape with 50mm Head	100 100 100 100	● ● ● ● ● ● ● ● ● ● ● ● ● ● ● ● ● ● ● ●
DGSSCS	DGS Suspension Clip Small is the standard height adjustable suspension clip connecting from 2.5mm or 5mm rod to the DGS Main Bar	100	● ● ●
DGSSCTR	DGS Threaded Rod Clip is a suspension clip for 6mm Threaded Rod	100	● ● ●

Flat Ceilings

Integrating Services

The Armstrong Drywall Grid System is designed to accommodate installation of mechanical services such as light fixtures and air registers. Fixtures can be simply framed regardless of orientation (parallel or perpendicular to Main Bars), as per the illustrations below.

Main Bars feature connection routs at 150mm centres for installation of additional Cross Runners so that fixtures can be framed and supported. The "3 Way Bite Clip" is applied where connections are required where no rout exists, such as connecting between Cross Runners.

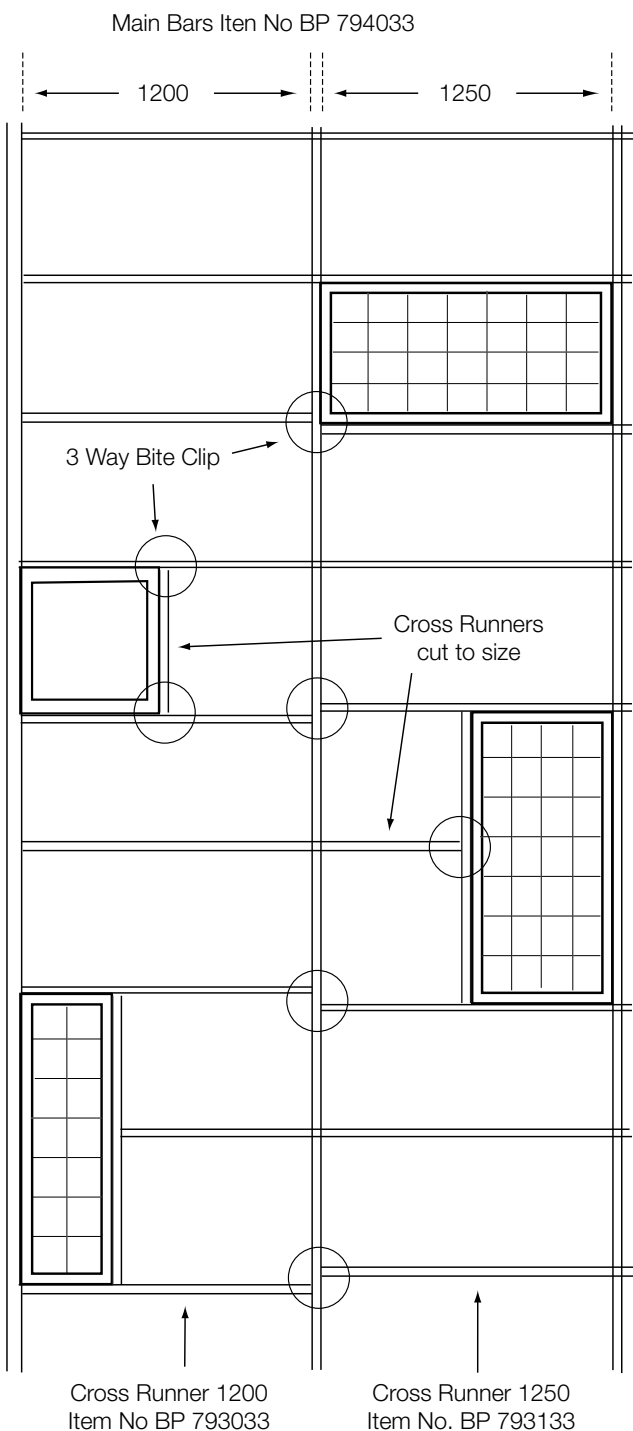

Note: Light Fixtures Installed Perpendicular to Main Bars

1. Main Bars should be installed at 1250mm OC to accommodate Light Fixtures, providing a clear opening of 1212mm for easy installation. Standard 1250mm long Cross Runners are installed between Main Bars at 600mm OC, with additional Cross Runners to support and frame out the fixtures.
2. For shorter rectangular fixtures, (with length less than 1162mm) install Main Bars at 1200mm OC and apply typical 1200mm Cross Runners.

Legend

-  3 Way Bite Clip to be installed at Cross Runner connection where no rout is available

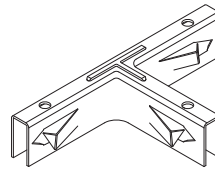

Squaring up the system

Ensure grid is square following installation of first two Main Runners

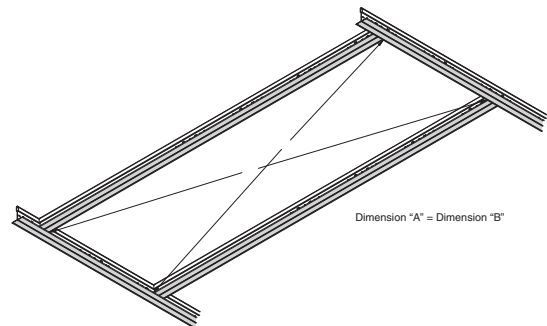

Flat Ceilings

System Details

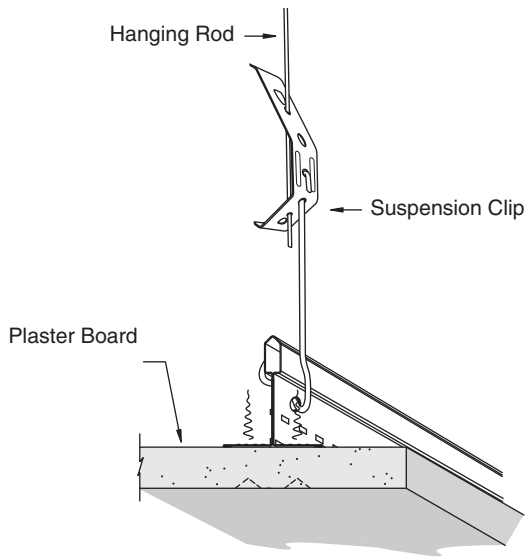

1 Suspension

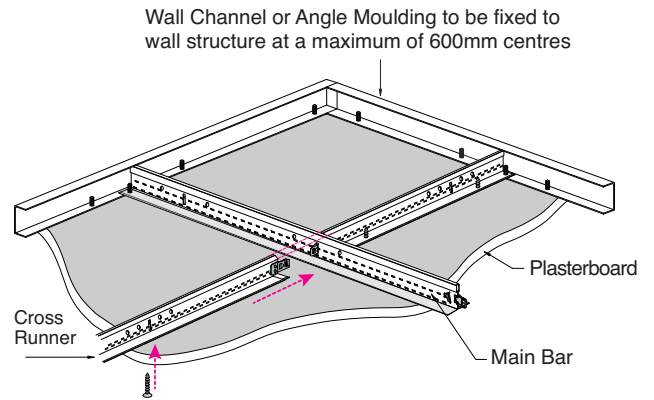

2 Perimeter Detail

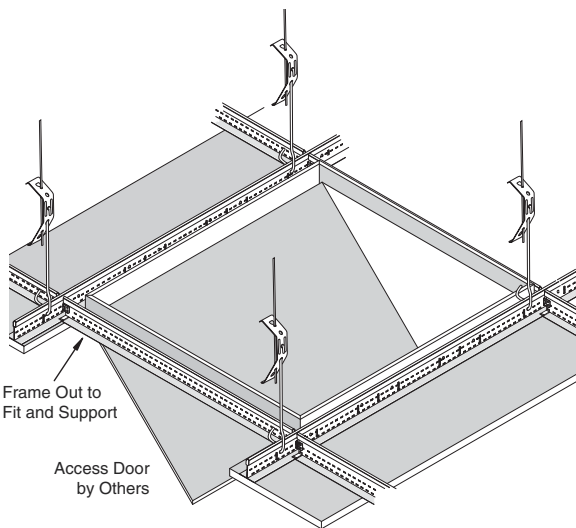

3 Access Door

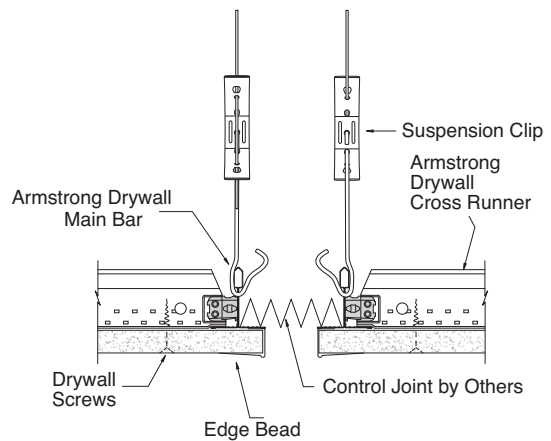

4 Control Joint

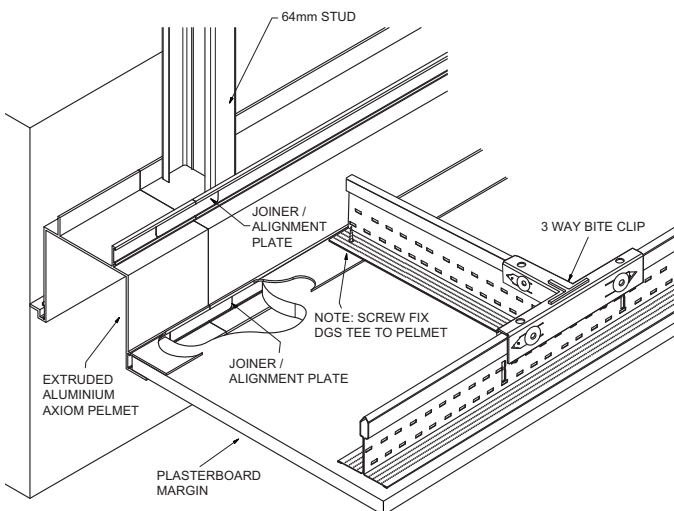

5 Pelmet

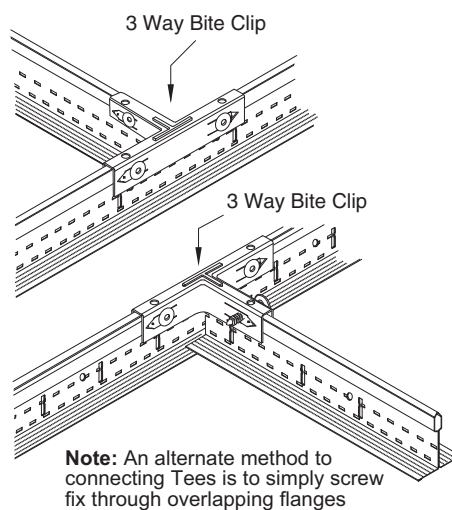

6 Securing a Single Cross Runner

Flat Ceilings

System Details

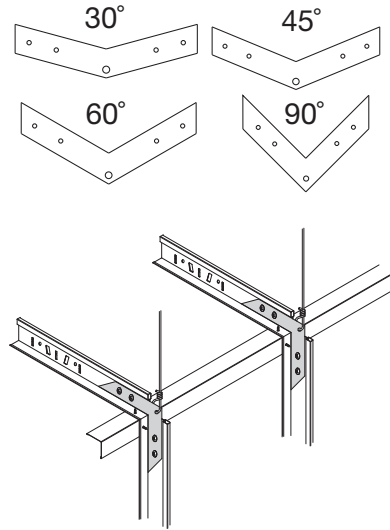
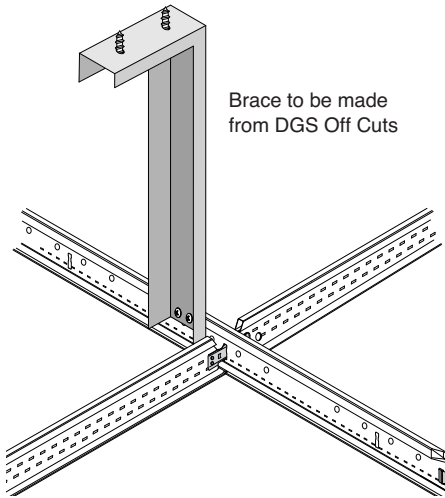

7 Alternative Suspension Method

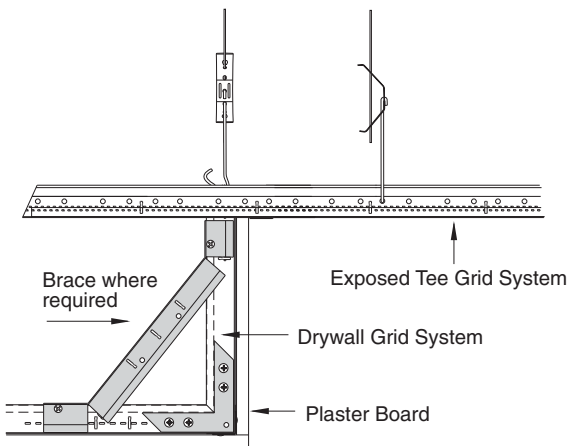

8 Angle Clip

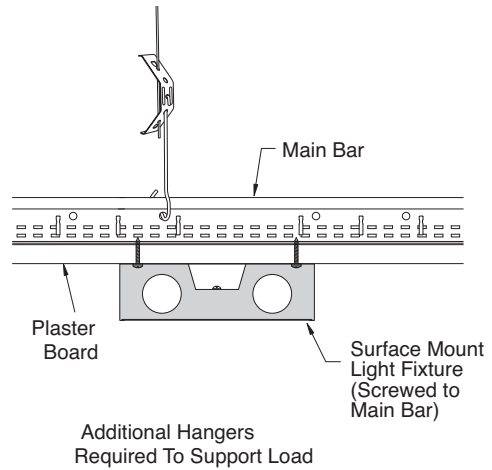

9 Bulkhead

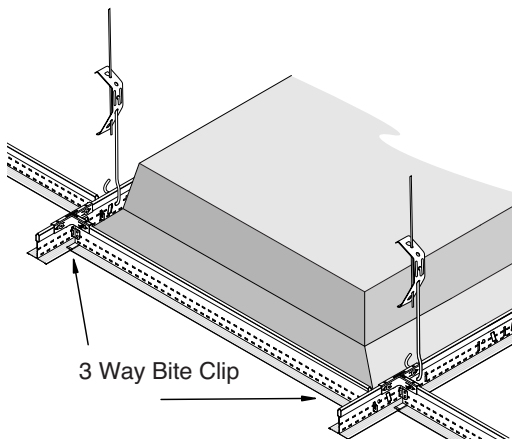

10 Surface Mount Fixture

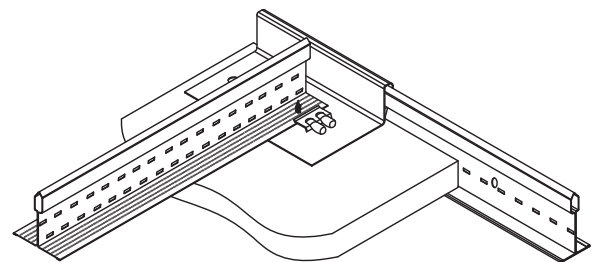

11 Light Fixture

12 Transition with DW10/13/16 Clip

Flat Ceilings

Suspension System – Grid Estimator Per 100m²

Reference 1

Main Bars @ 1200mm Centres / Suspension points @ 1200mm 1200mm Cross Runners @ 600mm Centres

Module 1200x600

CODE	Item	L/m	PCS	QTY
BP794033	DGS Main Bar 3600mm	83	23	2 Boxes
BP793033	DGS Cross Runner 1200mm	166	139	4 Boxes
SCDGS	Rod Hanging Clip		69	100 Pcs pack
BPKCM36	Knurled Channel Moulding	20	6	1 Box

Reference 2

Main Bars @ 1250mm Centres / Suspension points @ 1200mm 1250mm Cross Runners @ 600mm Centres

Module 1250x600

CODE	Item	L/m	PCS	QTY
BP794033	DGS Main Bar 3600mm	80	22	2 Boxes
BP793133	DGS Cross Runner 1250mm	166	133	4 Boxes
SCDGS	Rod Hanging Clip		66	100 Pcs pack
BPKCM36	Knurled Channel Moulding	20	6	1 Box

Reference 3

Main Bars @ 1600mm Centres / Suspension points @ 900mm 1600mm Cross Runners @ 600mm Centres

Module 1600x600

CODE	Item	L/m	PCS	QTY
BP794033	DGS Main Bar 3600mm	63	18	2 Boxes
BP796133	DGS Cross Runner 1600mm	169	106	3 Boxes
SCDGS	Rod Hanging Clip		72	100 Pcs pack
BPKCM36	Knurled Channel Moulding	20	6	1 Box

Reference 4

Main Bars @ 1200mm Centres / Suspension points @ 1200mm 1200mm Cross Runners @ 450mm Centres

Module 1200x450

CODE	Item	L/m	PCS	QTY
BP794033	DGS Main Bar 3600mm	83	23	2 Boxes
BP793033	DGS Cross Runner 1200mm	228	190	6 Boxes
SCDGS	Rod Hanging Clip		69	100 Pcs pack
BPKCM36	Knurled Channel Moulding	20	6	1 Box

Reference 5

Main Bars @ 1250mm Centres / Suspension points @ 1200mm 1250mm Cross Runners @ 450mm Centres

Module 1250x450

CODE	Item	L/m	PCS	QTY
BP794033	DGS Main Bar 3600mm	80	22	2 Boxes
BP793133	DGS Cross Runner 1250mm	225	180	4 Boxes
SCDGS	Rod Hanging Clip		66	100 Pcs pack
BPKCM36	Knurled Channel Moulding	20	6	1 Box

Reference 6

Main Bars @ 1600mm Centres / Suspension points @ 900mm 1600mm Cross Runners @ 450mm Centres

Module 1600x450

CODE	Item	L/m	PCS	QTY
BP794033	DGS Main Bar 3600mm	63	18	2 Boxes
BP796133	DGS Cross Runner 1600mm	222	139	4 Boxes
SCDGS	Rod Hanging Clip		72	100 Pcs pack
BPKCM36	Knurled Channel Moulding	20	6	1 Box

Flat Ceilings

Drywall Grid Board Loadings – Maximum Weight m²

Main Bar Centres mm	Cross Runner	Cross Runners Centres mm	Suspension Points	
			900mm	1200mm
1200mm	1200mm	450mm	2 x 16mm Plasterboard	1 x 13mm Plasterboard
	1200mm	600mm	2 x 16mm Plasterboard	1 x 13mm Plasterboard
1250mm	1250mm	450mm	2 x 16mm Plasterboard	1 x 13mm Plasterboard
	1250mm	600mm	2 x 13mm Plasterboard	1 x 13mm Plasterboard
1600mm	1600mm	450mm	1 x 16mm Plasterboard	Not Allowed
	1600mm	600mm	1 x 13mm plasterboard	Not Allowed

10mm Plasterboard	6.8kgs m ²
13mm Plasterboard	8.6kgs m ²
13mm Plasterboard	10.5kgs m ²
16mm Plasterboard	13kgs m ²
10mm Ceiling Board	7.2kgs m ²

Design Loads Based On Items Below

BP794033	3600mm Main Bar
BP796133	1600mm Cross Runner
BP793133	1250mm Cross Runner
BP793033	1200mm Cross Runner

Load Data

Module Size	Grid System Weight (kg/m ²)
1200 x 450	1.43
1200 x 600	1.17
1250 x 450	1.42
1250 x 600	1.16
1600 x 450	1.33
1600 x 600	1.08

Ceiling Load Calculator

To determine compliance of system (In accordance with AS/NZS 2785:2020), based on project requirements, apply the following calculator:

- Determine Dead Load (G) = Sum of following:
 - Plasterboard weight in kg/m² = A
 - Grid weight based on module (Fig 2) = B
 - Fixtures Load (Includes lights etc) = C
 Dead Load (G) = Sum (A+B+C) x 1.4 = _ kg/m²
- Add Service Load (U) = 3kg/m² x 1.7 = 5.1kg/m²
- Actual Ceiling Load = G + U = _kg/m²

4. For compliance to AS/NZS 2785:2020, the Calculated Ceiling Load (G+U) must be less than the System Capacity.

Note: Light fixtures and other mechanical services may require additional suspension points or be independently suspended.

Worked Example of Actual Project Ceiling Load: Using 13mm plasterboard and Grid Module: 1200x600mm

- Determine Dead Load (G) = Sum of following:
 - Plasterboard weight in 8.2kg/m² = A
 - Grid weight based on module (Fig 2) = 1.17kg/sm² = B
 - Fixtures Load (Includes lights etc) = Assume Nil based on light fixture = weight of plasterboard
 Dead Load (G) = Sum (A+B+C) x 1.4 = 13.12 kg/m²
- Add Service Load (U) = 3kg/m² x 1.7 = 5.1kg/m²
- Actual Ceiling Load = G + U = 18.21kg/m²
- System complies to AS/NZS 2785:2020, as the Calculated Ceiling Load (G+U) < 18.79kg/sm (being the System Capacity).

Architectural Specifications

Flat Plasterboard Ceilings: Suspended Grid shall be Armstrong Drywall Grid System, comprising of Main Bars and Cross Runners, including Wall Mouldings and Transition Trims, as per manufacturer's instructions.

Curved Plasterboard Ceilings: Suspended Grid shall be Armstrong Drywall Grid System, comprising of Main Bars (faceted) and Cross Runners, including Wall Mouldings and Transition Trims, as per manufacturer's instructions.

Corridors or Plasterboard Margins: Suspended Grid shall be Armstrong DGS ShortSpan, comprising of ShortSpan Tees and StrongBack Support sections (where required), including Wall Mouldings and Transition Trims as per manufacturer's instructions.

Bulkhead / Soffit: Suspended Grid structure shall be Armstrong DGS QuickStix, comprising of QuickStix Tees and Cross Runners, including Wall Mouldings and Transition Trims, as per manufacturer's instructions.

Wall Battening: Wall framing shall be Armstrong Drywall Grid System, comprising of ShortSpan, or Main Bar, including Knurled Channel mouldings, as per manufacturer's instructions.

Contact your Armstrong Office for additional project specification details.

For Seismic Design support please contact your local Armstrong Ceilings office.

Distributed by



Grayking Interior Supply

📞 NSW (02) 9666 6688
📞 QLD (07) 3267 6222
✉️ sales@grayking.com.au
🌐 grayking.com.au



Madex Linings & Ceiling Distributors

📞 VIC (03) 9336 2419
✉️ info@mlcd.com.au
🌐 mlcd.com.au



M & C Plaster Supply

📞 VIC (03) 9362 0214
✉️ info@mcplaster.com.au
🌐 mcplastersupplies.com.au