

CORTEGA



CORTEGA

BENEFITS

- High light reflectance for brighter space and increase energy savings.
- Non-Directional visual reduces installation time and scrap.
- Balanced noise absorption and attenuation performance.
- Loose dirt and particles cleanable with dry cloth or vacuum with soft brush attachment.
- Third party tested and certified by industry leading Eco-classification; deemed to be innovative, Eco-preferable nature and likely to contribute points to various green building assessment.

APPLICATION AREAS

- **Commercial Office**
Improve working productivity over hard surface ceilings. Absorb and attenuate unwanted noise.
- **Schools and Learning Institute**
Improve learning quality.
- **Retail**
Minimizing distraction and improve retail experience by treating excessive noise reverberation.
- **General Healthcare**
Improve indoor noise ambiance level; ideal for healing environment.
- **Factory**
Improve working and production productivity.

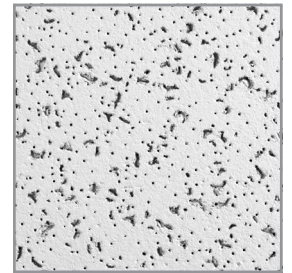

Inspiring Great Spaces™

Armstrong[®]
CEILING SOLUTIONS

CORTEGA

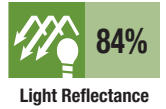

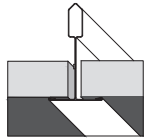
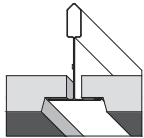
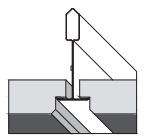
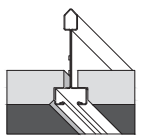
Armstrong Grid Options	SQUARE LAY-IN ^①	ANGLED TEGULAR ^②	BEVELED TEGULAR ^③	
	15/16" 24mm  Prelude Grid	15/16" 24mm  Prelude Grid	9/16" 15mm  Suprafine Grid	9/16" 15mm  Silhouette Grid
24 × 24 × 7/11"	3522	3528	—	
600 × 600 × 16mm	3523	3529	3553	
24 × 48 × 7/11"	3520	—	—	
600 × 1200 × 16mm	3521	—	—	

Remarks: ① & ② 24mm (15/16") Exposed Tee Grid; ③ 15mm (9/16") Exposed Tee Grid

* Special items and other sizes available upon request



NRC 0.55



CAC 33



RH 99% at 0°C-49°C



BS476 part 6 & 7 Class 0/Class 1
US: Class A – Flame Spread 25 or under



Thermal Insulation (R-Value)
0.26 m²K/W



3522, 3523, 3553, 3528, 3529	3520, 3521
3.30 kgs/m ²	3.40 kgs/m ²
(0.67 lbs/SF)	(0.69 lbs/SF)

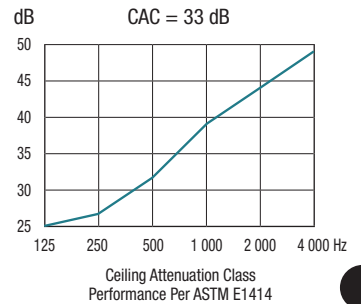
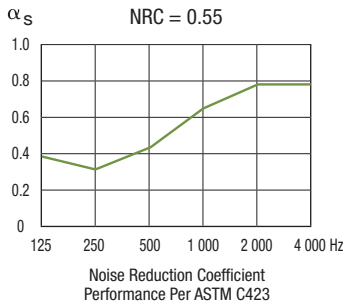

Material

Wet-formed Mineral Fibre

Surface Finish

Factory-applied acrylic latex paint with "BioBlock mold/mildew inhibitor"

Warranty

Armstrong commercial suspension systems and commercial ceiling products have a 30 year limited system warranty when installed together



Armstrong provides the widest selection of environmental preferred products that have been third party tested and certified by industry leading Eco-classification.

Please contact your Armstrong representative for list of compliant certifications.

Sales and Technical Support
asia_support@armstrongceilings.com



Cortega is a medium textured product with some inherent fissures from our production process and it does not constitute product defect.